



## Declaration of Independence

The main purpose of America's Declaration of Independence was to explain to foreign nations why the colonies had chosen to separate themselves from Great Britain. The Revolutionary War had already begun, and several major battles had already taken place. The American colonies had already cut most major ties to England, and had established their own congress, currency, army, and post office. On June 7, 1776, at Independence Hall in Philadelphia, Richard Henry Lee voiced a resolution that the United States ought to be completely free of England's influence, and that all political ties between the two countries should be dissolved. Congress agreed and began plans to publish a formal declaration of independence and appointed a committee of five members to draft the declaration.

Thomas Jefferson was chosen to draft the letter - which he did in a single day. Four other members, Roger Sherman, Robert Livingston, Benjamin Franklin and John Adams were part of the committee to help Jefferson. In the Declaration of Independence, Jefferson explained that a body of people has a right to change governments if that government becomes oppressive (unfair and controlling). He further explained that governments fail when they no longer have the consent of the governed. Since Parliament clearly lacked the consent of the American colonists to govern them, it was no longer legitimate.

The Declaration was presented to the Continental Congress in Philadelphia, Pennsylvania on July 2, 1776. It was approved with a few minor changes. Of the 56 signers of the Declaration of Independence, John Hancock, of Massachusetts was the first.



**1.) Why was the Declaration of Independence written?**

- A. For the colonists
- B. For the British
- C. For the kings
- D. For other nations

**2.) Which of the following HAD NOT taken place before the Declaration of Independence was written?**

- A. Battles
- B. America had named a president
- C. The Revolutionary War
- D. American had cut most ties with England

**3.) In the following sentence, what does the word "influence" mean?**

Richard Henry Lee voiced a resolution that the United States ought to be completely free of England's influence

- A. battle
- B. royal family
- C. under the effect of
- D. money

**4.) Which of the following is an accurate description of what Thomas Jefferson described in the Declaration?**

- A. That the King of England owes the colonists money
- B. That America will win the war against England
- C. People have the right to fair government
- D. The colonists have no rights

**5.) According to Jefferson, when do governments fail?**

- A. When they no longer have the consent of the people
- B. When they fight wars
- C. When they issue taxes
- D. When they owe money

**6.) Which of the following is NOT a reason the Declaration of Independence was written?**

- A. Parliament lacked consent of the American people
- B. Parliament was unfair
- C. Parliament taxed the Americans
- D. Parliament had failed the American people

**7.) The Continental Congress....**

- A. Agreed to the Declaration with a few changes
- B. Totally and completely agreed with the Declaration
- C. Disagreed with the Declaration
- D. Agreed with the Declaration, but made major changes

**8.) Which of the following describes an illegitimate government according to the Declaration?**

- A. A government that taxes its people
- B. A government that oppresses its people
- C. A government that has the consent of its people
- D. A government run by the people

**9.) The British were....**

- A. Likely to agree to the declaration
- B. Likely to disagree to the declaration
- C. Likely to agree to the declaration with a few minor changes
- D. Likely to agree to the declaration with a few major changes

**10.) Which of the following is FALSE?**

- A. Congress established a taxing system before the Declaration of Independence
- B. Congress established a post office before the Declaration of Independence
- C. Congress established an army before the Declaration of Independence
- D. Richard Henry Lee voiced the resolution that American should dissolve its ties to England



**BLIZZARD BAG**  
**6<sup>TH</sup> GRADE MATH LESSON #2**



Hello 6<sup>th</sup> grade student. In order for our snow day to be excused, you must complete your Blizzard Bag lessons. For math, you will be reviewing basic operations: addition, subtraction, multiplication, and division. **Please show your work.** YOU MAY NOT USE A CALCULATOR!

I hope you are warm and cozy today!

*Mrs. Mock*



\* Complete the problems that have the problem number circled.



Student Name: \_\_\_\_\_

Score: \_\_\_\_\_

Addition

1)

$$\begin{array}{r} 3568 \\ + 2154 \\ \hline \\ \hline \end{array}$$

2)

$$\begin{array}{r} 5212 \\ + 6426 \\ \hline \\ \hline \end{array}$$

3)

$$\begin{array}{r} 6349 \\ + 1833 \\ \hline \\ \hline \end{array}$$

4)

$$\begin{array}{r} 8164 \\ + 7915 \\ \hline \\ \hline \end{array}$$

5)

$$\begin{array}{r} 2128 \\ + 9358 \\ \hline \\ \hline \end{array}$$

6)

$$\begin{array}{r} 4912 \\ + 2728 \\ \hline \\ \hline \end{array}$$

7)

$$\begin{array}{r} 1038 \\ + 3611 \\ \hline \\ \hline \end{array}$$

8)

$$\begin{array}{r} 6854 \\ + 7056 \\ \hline \\ \hline \end{array}$$

9)

$$\begin{array}{r} 8743 \\ + 2326 \\ \hline \\ \hline \end{array}$$

10)

$$\begin{array}{r} 3926 \\ + 1197 \\ \hline \\ \hline \end{array}$$

11)

$$\begin{array}{r} 2563 \\ + 7151 \\ \hline \\ \hline \end{array}$$

12)

$$\begin{array}{r} 4252 \\ + 3227 \\ \hline \\ \hline \end{array}$$

13)

$$\begin{array}{r} 3543 \\ + 9307 \\ \hline \\ \hline \end{array}$$

14)

$$\begin{array}{r} 1267 \\ + 2759 \\ \hline \\ \hline \end{array}$$

15)

$$\begin{array}{r} 7825 \\ + 5465 \\ \hline \\ \hline \end{array}$$

16)

$$\begin{array}{r} 5715 \\ + 1659 \\ \hline \\ \hline \end{array}$$

17)

$$\begin{array}{r} 2634 \\ + 7093 \\ \hline \\ \hline \end{array}$$

18)

$$\begin{array}{r} 1972 \\ + 1129 \\ \hline \\ \hline \end{array}$$

19)

$$\begin{array}{r} 6753 \\ + 3623 \\ \hline \\ \hline \end{array}$$

20)

$$\begin{array}{r} 7255 \\ + 2371 \\ \hline \\ \hline \end{array}$$





Student Name: \_\_\_\_\_

Score: \_\_\_\_\_

**Subtraction**

Subtract:

1) 
$$\begin{array}{r} 732 \\ - 61 \\ \hline \\ \hline \end{array}$$

2) 
$$\begin{array}{r} 377 \\ - 34 \\ \hline \\ \hline \end{array}$$

3) 
$$\begin{array}{r} 211 \\ - 89 \\ \hline \\ \hline \end{array}$$

4) 
$$\begin{array}{r} 786 \\ - 57 \\ \hline \\ \hline \end{array}$$

5) 
$$\begin{array}{r} 662 \\ - 45 \\ \hline \\ \hline \end{array}$$

6) 
$$\begin{array}{r} 978 \\ - 28 \\ \hline \\ \hline \end{array}$$

7) 
$$\begin{array}{r} 208 \\ - 16 \\ \hline \\ \hline \end{array}$$

8) 
$$\begin{array}{r} 932 \\ - 75 \\ \hline \\ \hline \end{array}$$

9) 
$$\begin{array}{r} 526 \\ - 84 \\ \hline \\ \hline \end{array}$$

10) 
$$\begin{array}{r} 697 \\ - 31 \\ \hline \\ \hline \end{array}$$

11) 
$$\begin{array}{r} 932 \\ - 62 \\ \hline \\ \hline \end{array}$$

12) 
$$\begin{array}{r} 876 \\ - 53 \\ \hline \\ \hline \end{array}$$

13) 
$$\begin{array}{r} 159 \\ - 99 \\ \hline \\ \hline \end{array}$$

14) 
$$\begin{array}{r} 842 \\ - 26 \\ \hline \\ \hline \end{array}$$

15) 
$$\begin{array}{r} 658 \\ - 74 \\ \hline \\ \hline \end{array}$$

16) 
$$\begin{array}{r} 441 \\ - 38 \\ \hline \\ \hline \end{array}$$

17) 
$$\begin{array}{r} 263 \\ - 12 \\ \hline \\ \hline \end{array}$$

18) 
$$\begin{array}{r} 354 \\ - 97 \\ \hline \\ \hline \end{array}$$

19) 
$$\begin{array}{r} 558 \\ - 69 \\ \hline \\ \hline \end{array}$$

20) 
$$\begin{array}{r} 873 \\ - 32 \\ \hline \\ \hline \end{array}$$



Student Name: \_\_\_\_\_

Score: \_\_\_\_\_

### Multiply the Numbers

1) $\begin{array}{r} 94 \\ \times 12 \\ \hline \end{array}$	2) $\begin{array}{r} 61 \\ \times 39 \\ \hline \end{array}$	3) $\begin{array}{r} 86 \\ \times 54 \\ \hline \end{array}$	4) $\begin{array}{r} 78 \\ \times 43 \\ \hline \end{array}$
5) $\begin{array}{r} 99 \\ \times 26 \\ \hline \end{array}$	6) $\begin{array}{r} 53 \\ \times 68 \\ \hline \end{array}$	7) $\begin{array}{r} 25 \\ \times 12 \\ \hline \end{array}$	8) $\begin{array}{r} 36 \\ \times 49 \\ \hline \end{array}$
9) $\begin{array}{r} 18 \\ \times 64 \\ \hline \end{array}$	10) $\begin{array}{r} 12 \\ \times 28 \\ \hline \end{array}$	11) $\begin{array}{r} 35 \\ \times 43 \\ \hline \end{array}$	12) $\begin{array}{r} 29 \\ \times 67 \\ \hline \end{array}$
13) $\begin{array}{r} 87 \\ \times 25 \\ \hline \end{array}$	14) $\begin{array}{r} 75 \\ \times 15 \\ \hline \end{array}$	15) $\begin{array}{r} 68 \\ \times 34 \\ \hline \end{array}$	16) $\begin{array}{r} 91 \\ \times 72 \\ \hline \end{array}$
17) $\begin{array}{r} 76 \\ \times 53 \\ \hline \end{array}$	18) $\begin{array}{r} 27 \\ \times 55 \\ \hline \end{array}$	19) $\begin{array}{r} 16 \\ \times 98 \\ \hline \end{array}$	20) $\begin{array}{r} 24 \\ \times 32 \\ \hline \end{array}$



Name: \_\_\_\_\_

Score: \_\_\_\_\_

Division

1)  $6 \overline{) 231}$

2)  $3 \overline{) 586}$

3)  $9 \overline{) 672}$

4)  $4 \overline{) 407}$

5)  $7 \overline{) 915}$

6)  $2 \overline{) 353}$

7)  $5 \overline{) 728}$

8)  $8 \overline{) 246}$

9)  $4 \overline{) 522}$

10)  $8 \overline{) 841}$

11)  $9 \overline{) 440}$

12)  $6 \overline{) 119}$

13)  $2 \overline{) 731}$

14)  $5 \overline{) 865}$

15)  $8 \overline{) 975}$

16)  $3 \overline{) 329}$

17)  $4 \overline{) 515}$

18)  $6 \overline{) 154}$

19)  $7 \overline{) 426}$

20)  $5 \overline{) 293}$



6th grade  
science

# Blizzard Bag #2

Mrs. Davis

## LENGTH

1. What is the length (in inches) of the lines below?

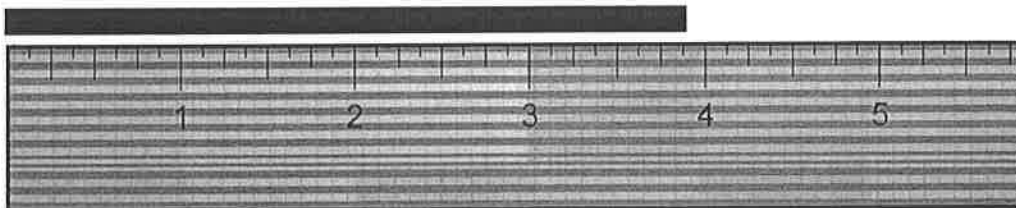

length = \_\_\_\_\_

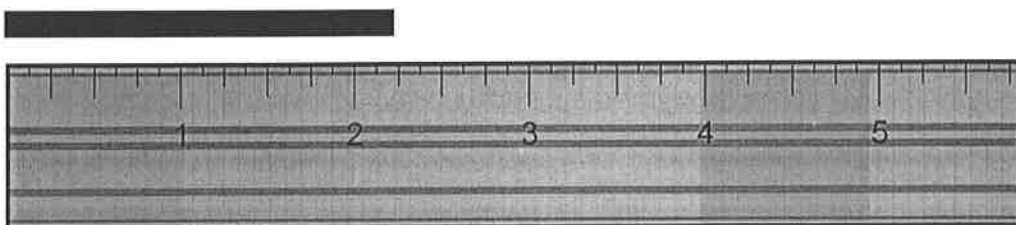

length = \_\_\_\_\_

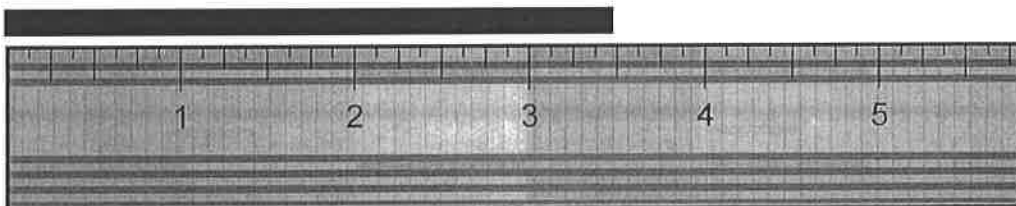

length = \_\_\_\_\_

2. What is the length (in centimeters) of the lines below?

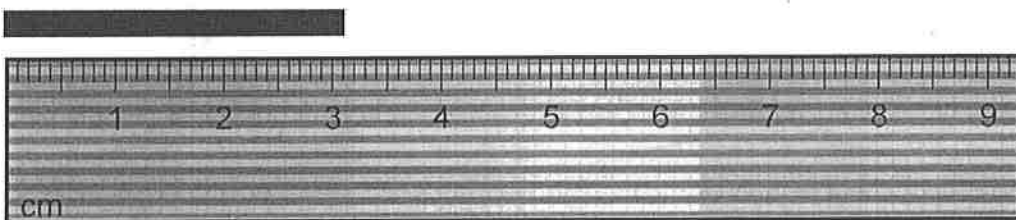

length = \_\_\_\_\_





6th grade Science

# Blizzard Bag #2

Mrs. Davis

4. Assuming that the pointers have reached the "zero mark," what would be the mass of the objects according to the movable masses below?

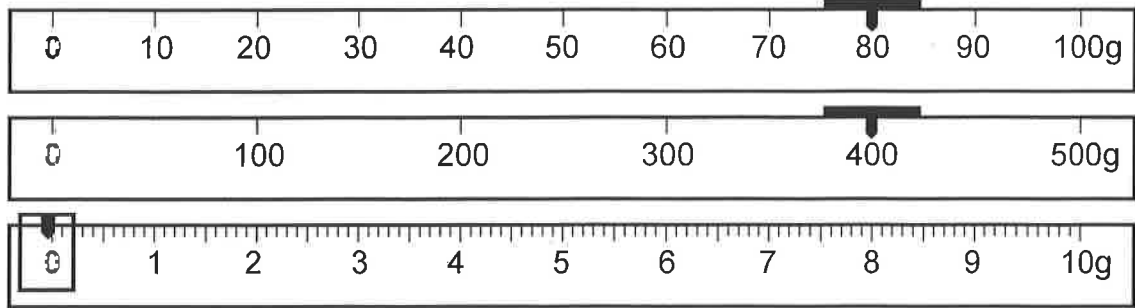

mass = \_\_\_\_\_

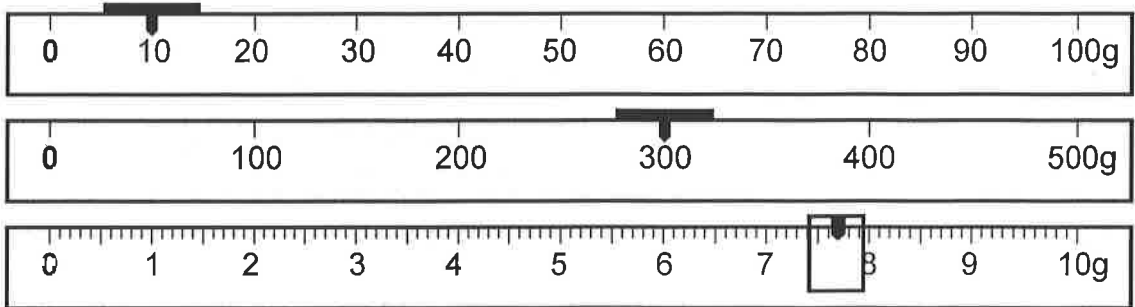

mass = \_\_\_\_\_

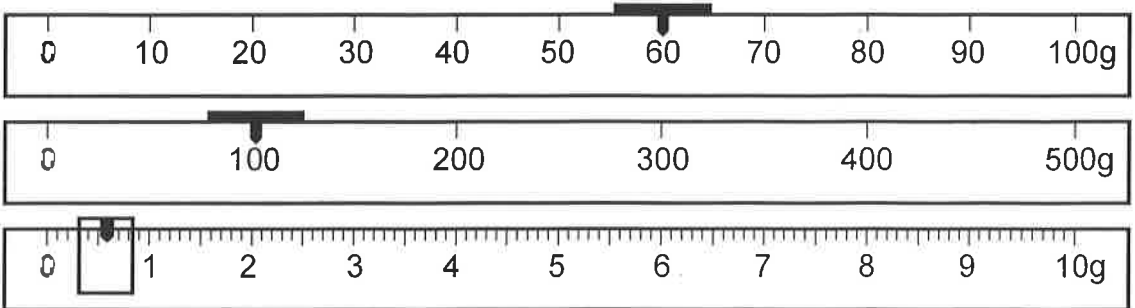

mass = \_\_\_\_\_



# Egypt's Extraordinary Female Pharaoh

## Quest to Be Pharaoh

Hatshepsut did not acquire power easily. Her father arranged for Hatshepsut to be married to Thutmose II. The two of them ruled together after her father's death. After the death of her husband, Thutmose II, Hatshepsut lost her power. Thutmose III became the pharaoh. Because he was too young to rule, Hatshepsut ruled as his regent.

Hatshepsut always felt, however, that she deserved to be the real pharaoh. She decided to prove she was worthy of the title by claiming to be divine. She believed her father was the Egyptian god, Amon, who took the form of Thutmose I. She also claimed that because she was her father's favorite child, she deserved to be his heir.

## Hatshepsut Declared Pharaoh

Hatshepsut resented having to rule on behalf of Thutmose III. In about 1479 B.C., Hatshepsut declared herself to be the real pharaoh. In order to play the part of the pharaoh, Hatshepsut decided to act like a man. She wore the traditional royal clothing of a pharaoh. She even went so far as to wear a fake beard! She declared herself to be "King of Upper and Lower Egypt." Hatshepsut ordered a great temple to be built in her honor. Two enormous granite pillars, called obelisks, were placed at the entrance to the temple. Stonecutters carved words of praise to Hatshepsut.

## Hatshepsut's Rule

Hatshepsut proved to be a very successful leader. She had old temples that had been damaged in battles restored. Hatshepsut sent a trade expedition to Punt to bring back gold, ivory, leopard skins, ostrich feathers, and other precious items for Egypt. She sent workers back into the desert to mine for rich ores. Her greatest success, however, was the 20 years of peace Egypt enjoyed.

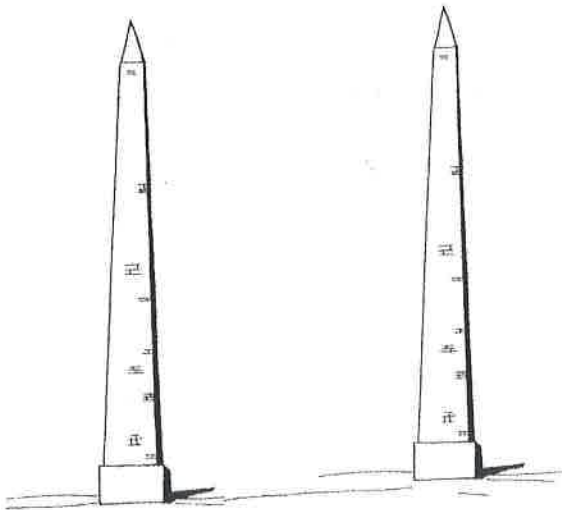

Each obelisk was 97 feet (30 m) tall.

## End of an Era

Hatshepsut's rule was under constant threat of revolt. As Thutmose III grew older, he resented her claim to the throne. Hatshepsut mysteriously disappeared. After her disappearance, Thutmose III declared himself to be the rightful pharaoh. He destroyed all images and references to Hatshepsut. Although there is no solid proof, legend has it that Thutmose III murdered Hatshepsut to regain the throne.

Name \_\_\_\_\_

## Egypt's Extraordinary Female Pharaoh

Fill in the bubble to answer each question or complete each sentence.

1. Which group of words best describes Hatshepsut?
  - (A) beautiful, young, and kind
  - (B) bold, shrewd, and skillful
  - (C) successful, smart, and humble
  - (D) weak, mild, and fearful
2. Which of these reasons did Hatshepsut give to convince people that she deserved to be pharaoh?
  - (A) Hatshepsut said she was her father's favorite child, so she should be his heir.
  - (B) Hatshepsut said it was time women were in charge.
  - (C) Hatshepsut said she learned how to rule well from her husband.
  - (D) Hatshepsut said she was really the god Amon.
3. When Hatshepsut declared herself pharaoh, she ordered \_\_\_\_\_.
  - (A) royal gowns and jewels to be made for her
  - (B) a temple and two obelisks to be built in her honor
  - (C) a pyramid to be built in her honor
  - (D) Thutmose III out of the country
4. Which of these was not one of Hatshepsut's achievements?
  - (A) trade expedition to Punt
  - (B) old temples restored
  - (C) 20 years of peaceful rule
  - (D) victory in war against Rome
5. Hatshepsut's rule was under constant threat of revolt from \_\_\_\_\_.
  - (A) Thutmose I
  - (B) Thutmose II
  - (C) Thutmose III
  - (D) Amon

**Bonus:** Do you think Thutmose III had Hatshepsut murdered? On the back of this page, write your opinion of what you think really happened to Hatshepsut.

